

Revision #	Revision Comments	Date
------------	-------------------	------

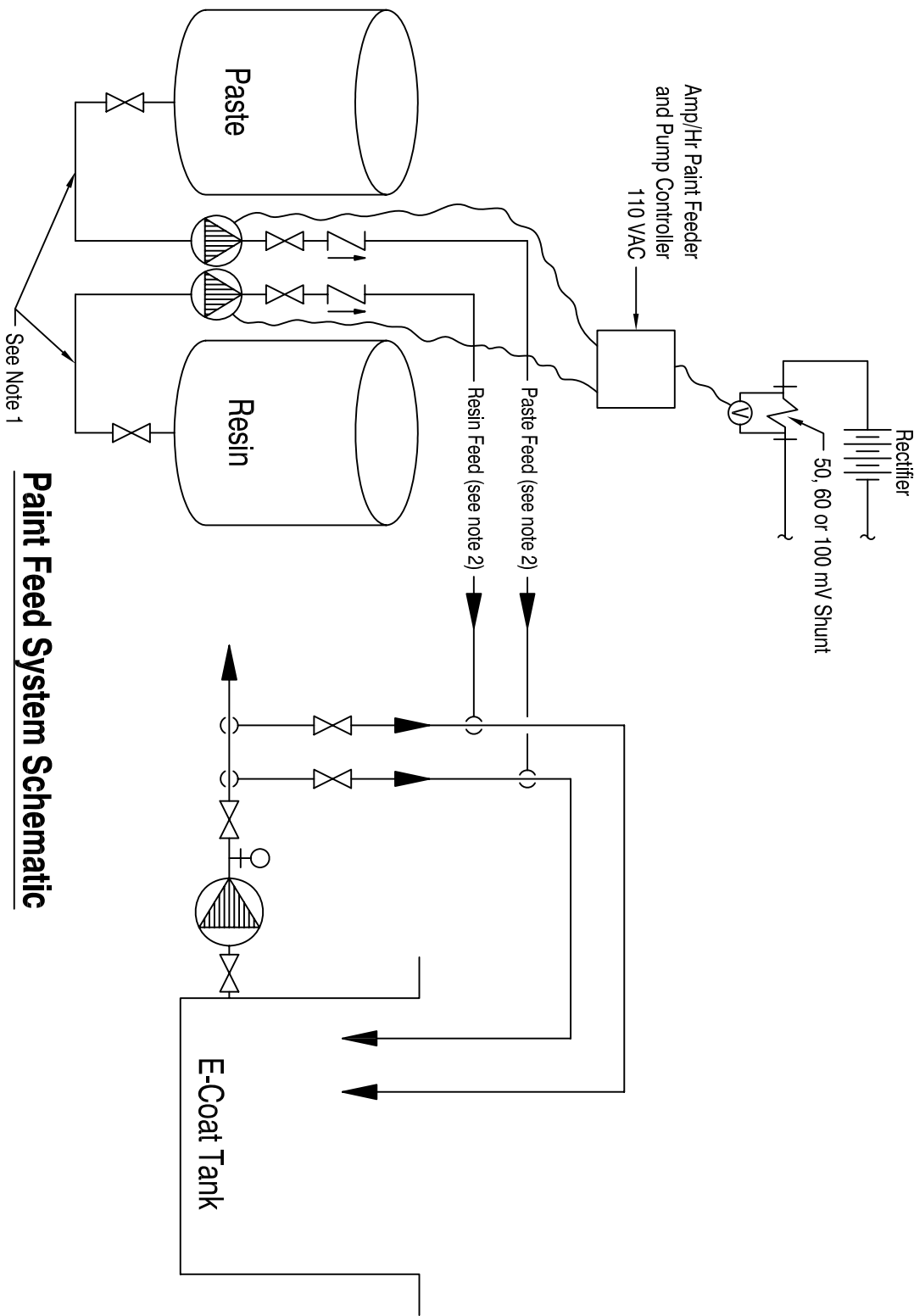

Paint Feed System Schematic

Notes:

1. Limit pump suction piping to no more than 36" and keep a 2" or however large the connector is on the paint tote/container. Only bush down the pipe size to the pump suction inlet right at the pump.
2. Feed Rate is 1.0 GPM into the middle leg of the tee for every 50-100 gpm flowing straight through the tee in order to achieve proper mixing.

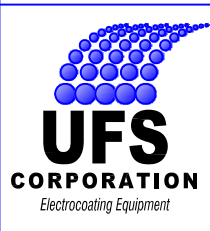

UFS Corporation
 330 North 400 East
 Valparaiso, IN 46383 USA
 Fax: (219) 464-8646
 Tel: (219) 464-2027
 Sales Ext. 17
 Customer Service Ext. 28
 Production Ext. 24
 Engineering Ext. 14
 Visit us on the WEB
 www.ufsc.com

SDwg,GA,Paint Feed Sys, 2 Comp

UFS PN:

997416

THIS DRAWING IS THE CONFIDENTIAL PROPERTY OF UFS CORPORATION AND SHOULD NOT BE USED IN ANY WAY DETRIMENTAL TO THE CORPORATION'S INTEREST. MATERIAL SHOULD NOT BE COPIED OR REPRODUCED IN PART OR IN WHOLE, AND INFORMATION FROM IT SHALL NOT BE FURNISHED TO OTHERS WITHOUT WRITTEN PERMISSION. ALL RIGHTS OF DESIGN AND INVENTION ARE RESERVED BY UFS CORPORATION. MATERIAL TO BE RETURNED UPON REQUEST.

Designed By:	Dickerson
Approved By:	Jovanovic
Date:	10/5/06
Sheet:	1/1
Units:	mm[in]
Scale:	None